

A New Way of Calculating Exact Exclusive Hypervolumes

Lucas Bradstreet, Lyndon While, Luigi Barone
The University of Western Australia

Abstract—We describe a new method for calculating the exclusive hypervolume of a point p relative to a front S . We use p to bound the objective values of the points in S , and subtract the hypervolume of the resulting front from the hypervolume of p alone. Early experiments show great promise for this approach, in both in-line and metric calculations.

Index Terms—Multi-objective optimisation, evolutionary computation, diversity, performance metrics, hypervolume.

I. INTRODUCTION

HYPERVOLUME [1], also known as the S-metric [2] or the Lebesgue measure [3], [4], is a popular metric in multi-objective optimisation. The hypervolume of a set of solutions measures the size of the portion of objective space that is dominated by those solutions collectively. Hypervolume captures in a single scalar both the closeness of the solutions to the optimal set and the spread of the solutions across objective space. It also has nicer mathematical properties than other metrics [4], [5].

Hypervolume is also used in-line in some evolutionary algorithms, as part of a diversity mechanism [6], as part of an archiving mechanism [7], or as part of the selection mechanism [8], [9]. The requirement in such cases is to compare the *exclusive hypervolume* contributed by different points, i.e. the amount by which each point increases the hypervolume of the set (see Fig. 1). Clearly, if hypervolume calculations are incorporated into the execution of an algorithm (as opposed to hypervolume used as a metric after execution is completed), there is a much stronger requirement for those calculations to be efficient.

II. CONTRIBUTION

The principal contribution of this paper is a new method for calculating the exclusive hypervolume of a point relative to a front. Using $Hyp(S)$ to represent the hypervolume of the set S , we can define exclusive hypervolume as in (1):

$$ExcHyp(p, S) = Hyp(S \cup \{p\}) - Hyp(S) \quad (1)$$

But as is clear from Fig. 2,

$$ExcHyp(p, S) = Hyp(\{p\}) - Hyp(S') \quad (2)$$

where

$$S' = \{limit(s, p) | s \in S\} \quad (3)$$

$$limit(\langle s_1, \dots, s_n \rangle, \langle p_1, \dots, p_n \rangle) = \langle worse(s_1, p_1), \dots, worse(s_n, p_n) \rangle \quad (4)$$

$limit(s, p)$ returns s with each objective value bounded by the corresponding objective in p : for example in a maximised objective $worse$ will return the smaller of its arguments. Dominated points in S' can be discarded before any further calculation is performed.

III. FURTHER WORK

We are developing algorithms that use (2) to calculate hypervolume both exclusively for in-line calculations, and as a metric, via (5):

$$Hyp(\{p_1, \dots, p_m\}) = \sum_{i=1}^m ExcHyp(p_i, \{p_{i+1}, \dots, p_m\}) \quad (5)$$

Early experiments show great promise for this approach.

REFERENCES

- [1] R. Purshouse, "On the evolutionary optimisation of many objectives," Ph.D. dissertation, The University of Sheffield, United Kingdom, 2003.
- [2] E. Zitzler, "Evolutionary algorithms for multiobjective optimization: Methods and applications," Ph.D. dissertation, Swiss Federal Institute of Technology (ETH) Zurich, Switzerland, 1999.
- [3] M. Laumanns, E. Zitzler, and L. Thiele, "A unified model for multi-objective evolutionary algorithms with elitism," in *Congress on Evolutionary Computation*, R. Eberhart, Ed. IEEE, 2000, pp. 46–53.
- [4] M. Fleischer, "The measure of Pareto optima: Applications to multi-objective metaheuristics," Institute for Systems Research, University of Maryland, Technical Report ISR TR 2002-32, 2002.
- [5] E. Zitzler, L. Thiele, M. Laumanns, C. M. Fonseca, and V. G. da Fonseca, "Performance assessment of multiobjective optimizers: An analysis and review," *IEEE Transactions on Evolutionary Computation*, vol. 7, no. 2, pp. 117–132, April 2003.
- [6] S. Huband, P. Hingston, L. While, and L. Barone, "An evolution strategy with probabilistic mutation for multi-objective optimization," in *Congress on Evolutionary Computation*, H. Abbass and B. Verma, Eds. IEEE, 2003, pp. 2284–2291.
- [7] J. Knowles, D. Corne, and M. Fleischer, "Bounded archiving using the Lebesgue measure," in *Congress on Evolutionary Computation*, H. Abbass and B. Verma, Eds. IEEE, 2003, pp. 2490–2497.
- [8] E. Zitzler and S. Künzli, "Indicator-based selection in multiobjective search," in *Parallel Problem Solving from Nature VIII*, ser. Lecture Notes on Computer Science, X. Yao, E. Burke, J. A. Lozano, J. Smith, J. J. Merelo-Guervos, J. A. Bullinaria, J. Rowe, P. Tino, A. Kaban, and H.-P. Schwefel, Eds., vol. 3242. Springer-Verlag, 2004, pp. 832–842.
- [9] M. Emmerich, N. Beume, and B. Naujoks, "An EMO algorithm using the hypervolume measure as selection criterion," in *Evolutionary Multi-objective Optimisation*, ser. Lecture Notes on Computer Science, C. A. Coello Coello, A. H. Aguirre, and E. Zitzler, Eds., vol. 3410. Springer-Verlag, 2005, pp. 62–76.

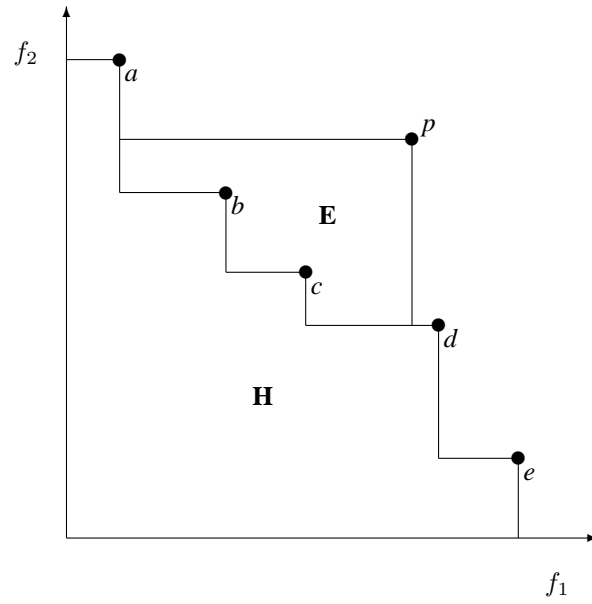

Fig. 1. Maximising in both objectives relative to the origin, the hypervolume of $\{a, b, c, d, e\}$ is the shape labeled H , and the exclusive hypervolume of p relative to $\{a, \dots, e\}$ is the shape labeled E .

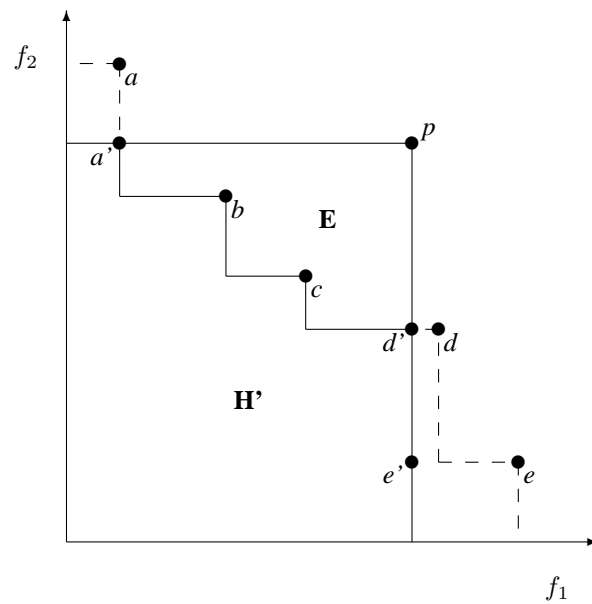

Fig. 2. The exclusive hypervolume of p (i.e. E) = the hypervolume of $\{p\}$ (i.e. the rectangle with p at the top-right corner) minus the hypervolume of $\{a', b, c, d', e'\}$ (i.e. H'). Clearly e' is dominated by d' and can be discarded.